

Step 3. Paring by entering serial number + Paring code (Owner).



Step 4. When you select option “pair manually”, just manually input Serial Number + Paring Code



Step 5. Review device license agreement and sign it.

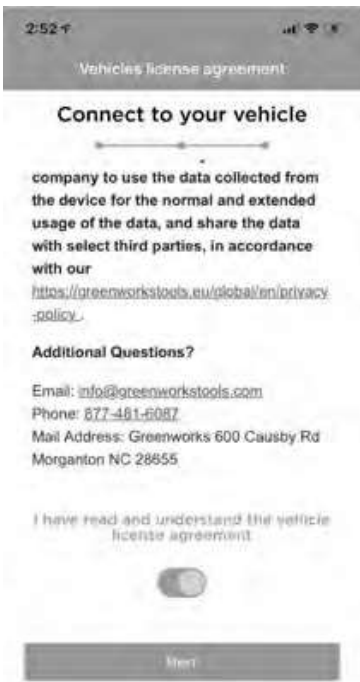

12.4 GPS FUNCTION

1. Upload data

Connect your mobile phone to the APP, and you can check fault, speed, and battery power of the machine through the APP.

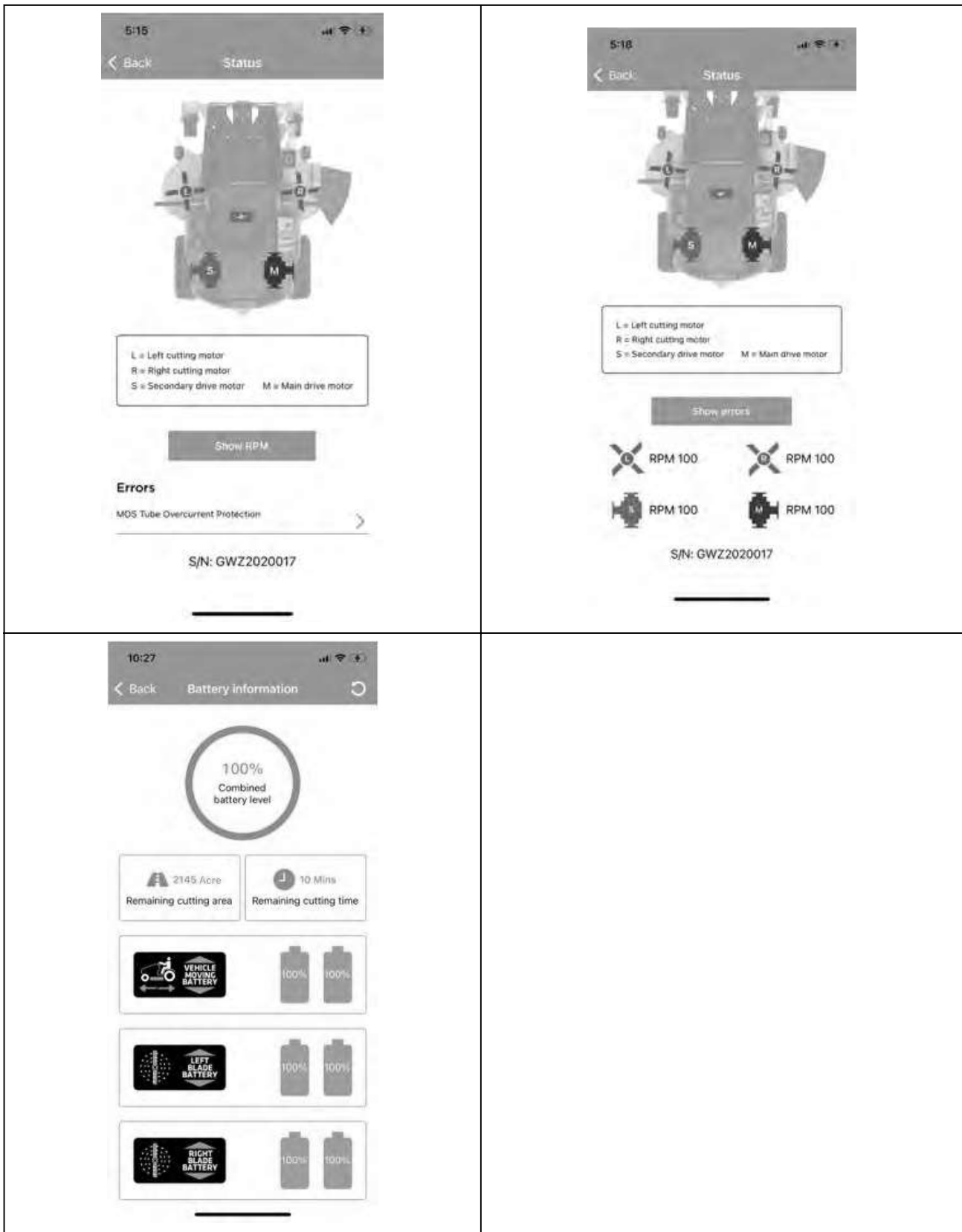

2. GPS

The machine is equipped with GPS function, you can connect your mobile phone to the machine by the APP. It is convenient to locate your machine and achieve anti-theft effect.

This icon shows the position where the vehicle was last connected on map.



When click vehicle icon, it will show the device's name, latest latitude and longitude.

Click the copy icon to copy the value of latitude and longitude.



▲ WARNING

The 4G & GPS connectivity device may lose the GPS satellite signal or cellular connection at any time. Due to heavy tree canopies, large buildings, poor weather conditions, electrical interference, dead zones, or other obstacles.

13 FAULT CODE

Dis-play	Description		Fault code on LCD	Cause	Solution
⚠	The left steering control lever fails.	The potentiometer on the left steering control lever fails.	V17	The potentiometer fails.	Contact a specified service center.
		The potentiometer connector on the left steering control lever is loose.		The connector is loose.	
⚠	The right steering control lever fails.	The potentiometer on the right steering control lever fails.	V18	The potentiometer fails.	Contact a specified service center.
		The potentiometer connector on the right steering control lever is loose.		The connector is loose.	
⚠	The machine does not work when the machine is powered on.	Before the machine is powered on, the PTO switch is ON.	V15	Before the machine is powered on, the PTO switch, left steering control lever, and right steering control lever are not in the initial position.	Turn off the PTO switch.
		Before the machine is powered on, the left steering control lever is ON.			Turn off the left steer control lever.
		Before the machine is powered on, the right steering control lever is ON.			Turn off the right steer control lever.
		After the whole machine is powered on, the output signal of the left or right accelerator is abnormal.			Contact a specified service center.
		The PTO switch is on when the machine is powered on, but the operator is not in the seat.			V16
	The left steering control lever is not in the Neutral position when the machine is powered on, but the operator is not in the seat.	Make sure the left steering control lever is in the N position.			
	The right steering control lever is not in the Neutral position when the machine is powered on, but the operator is not in the seat.	Make sure the right steering control lever is in the N position.			
	The operator leaves the seat during operation.	Do not leave the seat. (except emergent conditions.)			
	The operator is in the seat, and the machine is powered on, one steering control lever is in the Neutral position but the other is not.	Return the steering control levers to the N position when the operator leaves the seat.			

Display	Description		Fault code on LCD	Cause	Solution
⚠	The left or right drive motor does not work.	The 9pin connector between the vehicle wire harness and the left drive controller is loose.	V11	The connector is loose.	Contact a specified service center.
		The 9pin connector between the vehicle wiring harness and the right drive controller is loose.	V14	The connector is loose.	Contact a specified service center.
		The 10pin connector between the vehicle wire harness and the battery compartment is loose.	V21	The connector is loose.	Contact a specified service center.
		The 4pin connector between the vehicle wiring harness and the seat switch is loose.	V27	The connector is loose.	Contact a specified service center.
		Poor contact of seat switch connector.		Seat switch fails.	
		The PCBA that controls the left and right drive motors fails.	TR13, TL13, TR22, TL22, TR24, TL24, TR25, TL25, TR32, TL32	The PCBA fails.	Contact a specified service center.
		The 16pin connector between the vehicle wire harness and the left controller is loose , Or the 16pin connector between the vehicle wire harness and the right controller is loose.	V31, TR23	The connector is loose.	Contact a specified service center.
		A high-voltage battery pack is inserted in the of the battery compartment.	TR11, TL11	Wrong battery pack applied.	Check the battery pack.
		A low-voltage battery pack is inserted in the of the battery compartment.	TR12, TL12	Wrong battery pack applied.	Check the battery pack.
The power of the battery pack in the of the battery compartment is too low.	The battery capacity is not high enough.				

Dis-play	Description		Fault code on LCD	Cause	Solution
⚙	The left or right drive motor does not work.	The right gearbox is stuck.	TR14	The right gearbox fails.	Contact a specified service center.
		The left gearbox is stuck.	TL14	The left gearbox fails.	Contact a specified service center.
		The 6pin connector between the right drive controller and the right drive motor is loose.	TR15	The connector is loose.	Contact a specified service center.
		The right drive motor fails.		The motor fails.	
		The 6pin connector between the left drive controller and the right drive motor is loose.	TL15	The connector is loose.	Contact a specified service center.
		The left drive motor fails.		The motor fails.	
		The connector between the right solenoid valve and the right drive controller is loose.	TR16	The connector is loose.	Contact a specified service center.
		The right solenoid valve fails.		The solenoid valve fails.	
		The connector between the left solenoid valve and the right drive controller is loose.	TL16	The connector is loose.	Contact a specified service center.
				The solenoid valve fails.	
⚙	The left or right drive motor does not work.	The left solenoid valve fails.		The solenoid valve fails.	
		The right drive controller temperature is too high.	TR17	The controller temperature is too high.	Power off the machine, and power on again after the controller cools down for a while.
		The left drive controller temperature is too high.	TL17		
		The right drive motor temperature is too high.	TR18	The motor temperature is too high.	Power off the machine, and power on again after the controller cools down for a while.
		The left drive motor temperature is too high.	TL18		
		The right drive motor fails.	TR21	The motor fails.	Contact a specified service center.
		The 6pin connector between the right drive motor and the right drive controller is loose.		The connector is loose.	
		The left drive motor fails.	TL21	The motor fails.	Contact a specified service center.
The 6pin connector between the left drive motor and the left drive controller is loose.	The connector is loose.				

Display	Description		Fault code on LCD	Cause	Solution
⚠	The left or right blade does not work.	The communication module of the left blade controller is damaged.	V 12	The left blade controller fails.	Contact a specified service center.
		The 30pin connector between the vehicle wiring harness and the left blade controller is loose.		The connector is loose.	
		The communication module of the right blade controller is damaged	V 13	The right blade controller fails.	Contact a specified service center.
		The 30pin connector between the vehicle harness and the right blade controller is loose.		The connector is loose.	
		The 10pin connector between the vehicle wiring harness and the battery compartment is loose.	V21	The connector is loose.	Contact a specified service center.
		The 4pin connector between the vehicle wiring harness and the seat switch is loose.	V27	The connector is loose.	Contact a specified service center.
		Poor contact of seat switch contactor.		Seat switch fails.	
		A high-voltage battery pack is inserted in the of the battery compartment.	ML11	Wrong battery pack applied.	Check the battery pack.
		A high-voltage battery pack is inserted in the of the battery compartment.	MR11	Wrong battery pack applied.	Check the battery pack.
		The left blade motor fails.	ML13	The motor fails.	Contact a specified service center.
		The right blade motor fails.	MR13	The motor fails.	Contact a specified service center.
		The left mowing motor is overloaded.	ML14	The motor shut down for protection.	Raise the deck height and reduce drive speed.
		The machine is blocked with grass and debris.			Clean the deck.
		The blade hit a hard object.			Restart the machine.
		The left mowing motor is overloaded.	MR14	The motor shut down for protection.	Raise the deck height and reduce drive speed.
		The machine is blocked with grass and debris.			Clean the deck.
The blade hit a hard object.		Restart the machine.			

Dis-play	Description		Fault code on LCD	Cause	Solution
⚠	The left or right blade does not work.	The 6pin connector between the left blade motor and the vehicle wire harness is loose.	ML15	The connector is loose.	Contact a specified service center.
		The left blade motor fails.		The motor fails.	
		The 6pin connector between the right blade motor and the vehicle wire harness is loose.	MR15	The connector is loose.	Contact a specified service center.
		The right blade motor fails.		The motor fails.	
		The PCBA that controls the left blade motor fails.	ML16, ML18	The PCBA fails.	Contact a specified service center.
		The PCBA that controls the right blade motor fails.	MR16, MR18	The PCBA fails.	Contact a specified service center.
		The phase wire connector between the left blade motor and the left blade controller is loose.	ML17	The connector is loose.	Contact a specified service center.
		The phase wire connector between the right blade motor and the right blade controller is loose.	MR17	The connector is loose.	Contact a specified service center.
		The left blade controller temperature is too high.	ML21	The controller temperature is too high.	Power off the machine, and power on again after the controller cools down for a while.
		The right blade controller temperature is too high.	MR21		
⚠	The left or right blade does not work.	The left blade motor fails.	ML22	The motor fails.	Contact a specified service center.
		The 6pin connector between the left blade motor and the left blade controller is loose.		The connector is loose.	
		The right blade motor fails.	MR22	The motor fails.	Contact a specified service center.
		The 6pin connector between the right blade motor and the left blade controller is loose.		The connector is loose.	
		The left blade motor temperature is too high.	ML23	The motor temperature is too high.	Power off the machine, and power on again after the controller cools down for a while.
		The right blade motor temperature is too high.	MR23		
		The 30pin connector between the vehicle wire harness and the right blade controller is loose.	ML25	The connector is loose.	Contact a specified service center.
		The 30pin connector between the vehicle wire harness and the right blade controller is loose.	MR25	The connector is loose.	Contact a specified service center.

Dis-play	Description		Fault code on LCD	Cause	Solution
⚡	The battery compartment alarms.	PMU is slightly overcurrent or PMU is slightly overtemperature.	PMU11	PMU is slightly overcurrent or PMU is slightly over temperature.	Do not use the machine too much to avoid machine shut down.
		The PMU shutdown protection is triggered.	PMU12	The working environment is bad, PMU protection triggered.	Restart the machine.
				The power of the machine is too low.	Check the battery capacity.
				The battery compartment fails.	Contact a specified service center.
		The battery inserted does not work (not specified battery).	PMU13	Battery pack is not applicable.	Defective battery pack applied.
Defective battery pack inserted.	Make sure the battery pack is OK.				

14 MAINTENANCE

Regular maintenance is the best prevention for costly downtime or expensive, premature repair. The following pages contain suggested maintenance information and schedules which the operator should follow on a routine basis. For more detailed information, refer to the website for your unit. Remain alert for unusual noises, as they could be signaling a problem. Visually inspect the machine for any abnormal wear or damage.

14.1 MOWER BLADE MAINTENANCE

Check the mower blades daily. They are the key to power efficiency and well-groomed turf. Keep them sharp -- a dull blade will tear rather than cut the grass, leaving a brown ragged top on the grass within a few hours. A dull blade also requires more power. Replace any blade that is bent, cracked or broken.

▲ WARNING

Never attempt to straighten a bent blade by heating, or weld a cracked or broken blade as the blade may break and cause serious injury. Replace worn or damaged blades.

▲ WARNING

Never work with blades while key is in the ignition switch. Turn key to "OFF" position, remove the battery packs from the machine. Block up mower when you must work under it. Wear gloves when handling blades. Always check for blade damage if mower strikes a rock, branch or other foreign objects!

▲ DANGER

Touch-up sharpening can be done with a file. Check the blades for balance following grinding. A commercial balancing tool is available through most hardware supply stores, or balancing can be done by placing the blade on an inverted line punch or 1/2" bolt. Blade should not lean or tilt. While spinning the blade slowly, it should not wobble. If blade is out of balance, true it up before reinstalling. Lay the blade on a flat surface and check for distortion. Replace any distorted blade.

▲ WARNING

- The blade sail (curved part) must be pointing upward toward the inside of the deck to ensure proper cutting.
- When mounting blades, rotate them after installation to ensure blade tips do not touch each other or sides of the mower.
- Failure to correctly torque the bolt may result in the loss of the blade, which can cause serious injury.
- Mower blades are sharp and can cut. Wear gloves and use extra caution when servicing them.

14.1.1 REPLACE THE BLADE

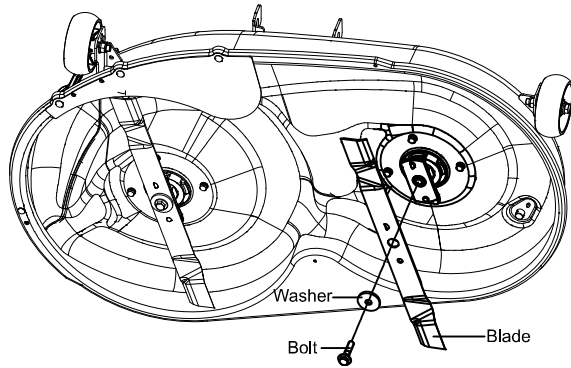

1. Stop the motor, remove the start key, and set the parking brake.
2. Raise the height of the cutting deck to its highest position to allow access to blades.

i NOTE

If necessary, raise the mower by placing on a lift or using a jack and jack stands, or remove the cutting deck as described in the previous section to gain access to the blades.

▲ WARNING

If raising the mower to access the blades, make sure the mower is properly secured and the parking brake is set before proceeding. Failure to properly secure the mower could cause it to fall, resulting in death or possible serious personal injury.

3. Wedge a block of wood between the blade and mower deck to prevent the blade from turning.
4. Loosen the blade nut by turning it counterclockwise (as viewed from bottom of mower) using a 16 mm wrench or socket (not provided).
5. Remove the blade nut, spacer, blade insulator, and blade.
6. Thread the blade nut on the shaft and finger tighten.
7. Torque the blade nut down clockwise using a torque wrench (not provided) to ensure the bolt is properly tightened. The recommended torque for the blade nut is 796~885 in. lbs.

▲ WARNING

Ensure blade is properly seated and the blade nut is tightened to the torque specifications above. Failure to properly attach the blade could cause it to come loose and result in possible serious personal injury.

8. Repeat with second blade, if needed.

i NOTE

Make certain all parts are replaced in the exact order in which they were removed.

14.2 TIRES

It is important for level mowing that all tires have the correct amount of air pressure. The recommended pressure are:

i NOTE

Tire pressure should only be measured or adjusted when tires are cold.

Front caster wheels	37 psi
Drive wheels	8 psi

i NOTE

Inspect the tires daily. Replace immediately if damaged.

▲ WARNING

Check the tire pressure carefully while inflating. Too much air in the tire could cause the tire to burst, causing serious personal injury.

14.3 LUBRICATION

Please add oil before operation.

Oil type	SAE85W-140
Oil capacity	180 ml

Contact your Greenworks dealer to replace the lubrication.

i NOTE

Replace the gearbox oil after you operate the machine for 50 hours for the first time, then replace the oil every 200 hours.

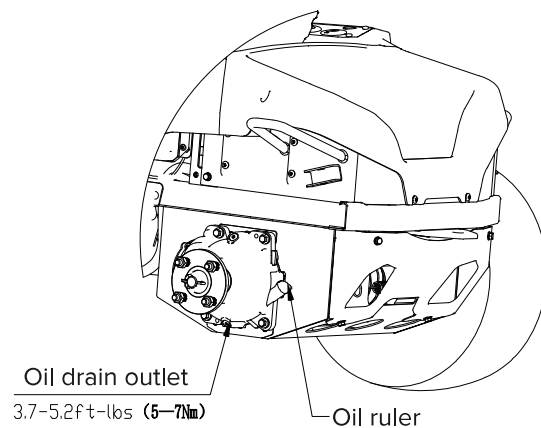

14.4 TORQUE VALUES

▲ WARNING

Particular attention must be given to tightening the drive wheel lug nuts and blade spindle bolts. Failure to correctly torque these items may result in the loss of a wheel or blade, which can cause serious damage or personal injury.

Torque values are given below:

Part	Ft-lbs.	Nm
Wheel (lug) nuts	89	120
Blade spindle bolt	66	90

Lug nuts only -It is recommended that these be checked after the first 2 hours of operation, initially, every 100 hours and following removal for repair or replacement.

For all other torques refer to the various mower parts manuals for standard torque chart.

14.5 BATTERY PACK MAINTENANCE

Your Greenworks mower is powered by a battery pack which, when maintained properly, will provide years of useful life. For proper care, adhere to the following instructions:

- Always charge batteries after each use.
- Whenever a battery pack is fully discharged and turned off, it is best to recharge the battery as soon as possible. Over-discharge of the battery pack means the battery life will be shortened and the battery may become permanently damaged. There is no need to fully charge; it will be beneficial even if you only charge the battery pack for 5-10 minutes. It is best to recharge it within 24 hours.
- Check that battery cables are securely tightened to batteries each time you service the battery.
- Keep grass, dirt and debris from collecting near battery terminals and in battery area.
- Charge batteries indoors in a well-ventilated and dry location away from sparks or flames. Never expose charger to rain, vapor or liquid.
- Charge only lithium batteries provided by Greenworks.
- Do not touch uninsulated portion of charger (terminal pins) or of output connector.
- Do not use with defective cords and wires. Replace defective cords and wires immediately.
- For long-term storage, please make sure the storage temperature is -4°F - 113°F within one month, and 32°F - 95°F between two and 12 months.
- The working environment of the battery pack is 14°F - 113°F. Battery pack can be used a -5°F - 131°F for discharge, and 32°F - 107°F for charge.

14.6 BATTERY COMPARTMENT FILTER MAINTENANCE

Replace the battery compartment filter every 200 hours.

14.7 SERVICE

i IMPORTANT

Wait for all movement to stop before adjusting, cleaning or repairing. Repairs or maintenance requiring power should be performed by trained maintenance personnel only. Read and observe safety warnings in front of manual.

i IMPORTANT

Repairs or maintenance requiring power should be performed by trained maintenance personnel only.

- Park the mower on level ground. Make sure that steering control levers are in the neutral position, and that the PTO switch is in “OFF” position. Raise deck, rotate key to “OFF” position, remove key from switch and remove the battery packs from the battery compartment under the seat.
- Any maintenance operation that requires the removal of safety covers must be performed by a trained service technician.
- Use a stick or similar instrument to clean under the mower, making sure that no part of the body -- especially arms and hands -- is under mower.
- Keep your machine clean and remove any deposits of trash and clippings.
- Keep battery compartment, deck and operator’s station clean of accumulated trash, grass clippings, and other debris.
- Clean battery compartment, drive motor compartment, mower deck, seat, etc., of all dirt and debris. To clean, use only compressed air. DO NOT use water, solvents, hard cleaners or abrasives.
- Always wear adequate eye protection when servicing the batteries or when grinding mower blades and removing accumulated debris. Never attempt to make any adjustments or repairs to the mower’s drive system, mower deck or any attachment while the traction drive system is running. Repairs or maintenance requiring power should be performed by trained maintenance personnel only.
- Never work under the machine or attachment unless it is safely supported with jack stands. Make certain machine is secure when it is raised and placed on the jack stands.
- The jack stands should not allow the machine to move when the traction drive system is running and the drive wheels are rotating. Use only certified jack stands. Use only appropriate jack stands, with a minimum weight rating of 2000 pounds (907.2 kg) to block the unit up. Use in pairs only. Follow the instructions supplied with the vehicle stands.
- Do not touch hot parts of machine.
- Keep nuts and bolts tight, especially the blade attachment bolts. Keep equipment in good working condition.
- Never tamper with safety devices. Check their proper operation regularly.

- Turn the key to the “OFF” position before unclogging the discharge chute.
- Never clear the discharge chute with the machine running. Turn the key to the “OFF” position and be sure the blades have stopped before cleaning. Use a stick to clear a plugged discharge area. Never use your hand!
- Stop unit and allow blades to stop before unclogging chute. Grass collection system components are subject to wear, damage and deterioration, which could expose moving parts or allow objects to be thrown. Frequently check components and replace with manufacturer’s recommended parts, when necessary.
- Exercise caution when working under the deck as the mower blades are extremely sharp. Wear gloves and use extra caution when servicing them.
- Use only genuine Greenworks Mower parts to ensure that original standards are maintained.
- Always remove batteries when transporting unit. Keep unit free of grass clippings, leaves and other debris.
- Check brake operation frequently. Adjust and service as required.
- Maintain or replace safety and instruction labels, as necessary.
- Have your ride-on lawn mower serviced by a qualified repair person using only identical replacement parts. This will ensure that the safety of the ride-on lawn mower is maintained.
- Recharge only with the charger specified by the manufacturer. A charger that is suitable for one type of battery pack may create a risk of fire when used with another battery pack.

15 TRANSPORTATION

▲ WARNING

Use extra care when loading or unloading the machine into a trailer. Press the low speed drive button and carefully move the drive levers as needed to control the speed. Always back onto the trailer when loading. When loading or unloading the mower, do not exceed the maximum recommended operation angle of 15°. Failure to follow these instructions can result in loss of control and result in death, serious personal injury, or property damage.

▲ WARNING

Use care when loading or unloading the mower onto a trailer. Ensure the cutting deck is raised to the highest position so that it is not caught on the ramp. The wheels on the mower can go off the ramp or trailer, causing the mower to pivot or tip over, and result in a crush hazard that can cause death or serious personal injury.

1. Park the mower on a level surface.
2. Raise the cutting deck to the highest position.
3. Position and secure ramp to the trailer according to manufacturer’s instructions.

i NOTE

We recommend you use one full width loading ramp that is at least 1 ft. wider than the mower to minimize the risk of the mower’s wheels going off the side of the ramp.

4. Slowly back the mower onto the ramp and into the trailer.
5. Lower mower deck completely.

6. Set the parking brake.
7. Turn off mower and remove key.
8. Secure the mower as needed using straps or cables to prevent movement during transport.

▲ WARNING

To avoid accidental starting or movement that could result in serious personal injury, always remove the start key and set the parking brake when transporting the mower.

16 CLEANING AND STORAGE

16.1 CLEAN THE MOWER DECK

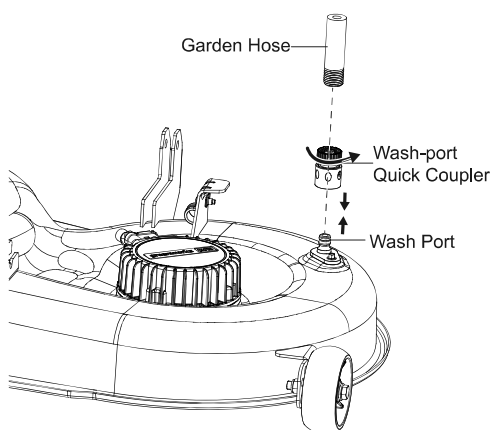

- Set the parking brake into the parking slots. Refer to section PARKING BRAKE SETTING in this manual.
- Adjust the mower deck height to the lowest. Refer to section "CUTTING-DECK HEIGHT ADJUSTMENT" in this manual.
- Attach the supplied wash-port quick-coupler to garden hose.
- Attach garden hose with quick-coupler to wash port on the mower deck. The wash port is on the left side of the mower deck.
- Turn on the water.
- Pull the PTO switch to start the mower cutting blades and adjust the blade speed to the highest. Refer to section "Blade-Speed Adjustment Button" in this manual.
- Flush water under the deck for approximately one minute.
- Disengage the mower blades by pushing the PTO switch downward.
- Turn off the water and remove garden hose and quick-coupler from wash port.
- Remove quick-coupler from garden hose and store for future use.
- Turn off the mower completely. See section "STOPPING THE ELECTRIC ZERO TURN MOWER".

16.2 STORE THE MACHINE

The following steps should be taken in order to prepare the machine for storage.

- Clean the machine as described in the previous section.
- Inspect the blade and replace it or sharpen it, if required (refer to the Maintenance section).
- Do not store the machine next to corrosive materials, such as fertilizer or rock salt.
- Keep the machine out of the reach of children.
- Do not cover the machine with a solid plastic sheet. Plastic coverings trap moisture around the machine, which causes rust and corrosion.
- Check thoroughly for any worn or damaged parts that need replacing and order them from your dealer.
- Thoroughly lubricate machine, according to lubrication instructions.
- Fully charge and service the batteries.
- Do not deflate tires.
- The machine should be stored in a well-ventilated, clean and dry place.

16.3 PREPARE FOR USE AFTER STORAGE

The following steps should be taken before using the mower after it has been stored:

- Fully charge the batteries.
- Check tire pressure and inflate as needed.
- Briefly drive the mower and check all systems and components to ensure they are functioning correctly.

17 TROUBLESHOOTING

Problem	Cause	Solution
The machine does not move.	<ol style="list-style-type: none"> 1. There is no battery pack in the battery compartment, or the battery inserted is not Greenworks designed. 2. The battery pack is out of power. 3. The steer control lever is in the NUETRAL position. 4. There is no person sitting on the seat or the seat switch is not connected. 5. The PTO switch, or the the left and right steer control levers are not in the original position when the machine power is on. 6. The battery pack that controls the drive function is in sleep state. 	<ol style="list-style-type: none"> 1. Make sure at least one Greenwoks designed battery pack is inserted in the battery compartment. 2. Check the battery capacity. 3. Make sure the steer control levers are not in the parking slots. 4. Make sure the operator is sitting on the seat. 5. Return the steer control lever and PTO switch to the original position, restart the machine. If the machine still fails to work, contact the service center for help. 6. Turn the key to the OFF position, and restart the machine 5 seconds later.
Sudden breakdown during driving.	<ol style="list-style-type: none"> 1. The battery is out of power. 2. The seat switch is disconnected on rugged or bumpy roads. 3. The accelerator fails. 4. The vehicle controller fails. 	<ol style="list-style-type: none"> 1. Make sure at least one Greenwoks designed battery pack is inserted in the battery compartment. Make sure the battery pack has power. 2. Return the steer control lever to original position, restart the machine, operate the steer control lever to check if the machine works normally. 3. Contact a technical people for help.
The blade fails to run when you pull up the PTO switch.	<ol style="list-style-type: none"> 1. There is no Greenwoks designed battery pack in the battery compartment. 2. The battery pack is out of power. 3. The seat switch is not connected. 4. The PTO switch is not pushed when the machine is powered on. 5. The blade motor is blocked or other functional protection. 	<ol style="list-style-type: none"> 1. Make sure at least one Greenwoks designed battery pack is inserted in the battery compartment. Make sure the battery pack has power. 2. Check the battery capacity. 3. Make sure the operator is sitting on the seat. 4. Push down on the PTO switch, restart the machine. 5. Cut the grass in low blade speed when you power on the machine, set the blade speed to high position once the machine cuts normally. Check if the connection between the blade and motor is without grass or foreign objects to ensure the blade rotates smoothly. 6. Turn the key to the OFF position, and restart the machine 5 seconds later.
The blade stops running during the mowing process.	<ol style="list-style-type: none"> 1. The blade motor is overheated. 2. The deck is full of grass and garbage. 3. The blade motor is overloaded. 4. The battery pack temperature is too high. 5. The battery is undervoltage. 6. The blade is hit by a foreign object, causing the blade to stop suddenly for protection. 	<ol style="list-style-type: none"> 1. Do not use the machine too much, power off the machine for 5min. Raise the deck height or reduce the driving speed to protect the blade. 2. Clean the deck to ensure that the blade rotation is normal. 3. Push down on the PTO switch; restart the machine. Raise the deck height or reduce the drive speed to protect the blade. 4. The battery pack that controls the blade system enters under-voltage protection state, and the battery should be charged immediately 5. Turn the key to the OFF position, and restart the machine 5 seconds later.

Problem	Cause	Solution
The machine cuts the grass unevenly.	<ol style="list-style-type: none"> 1. The blade is dull. 2. The blade is bent. 3. The deck is uneven. 	<ol style="list-style-type: none"> 1. Grind the blade according to the manual. 2. Replace the bent blade, replace the blade according to the instructions in the manual, and wear protective equipment. 3. Adjust the cutting deck according to the instructions in the manual to ensure the left and right deck height are even.
The actual cut height does not match the cut height you set.	<ol style="list-style-type: none"> 1. The bolt of the deck is loose. 2. The deck is severely worn or damaged. 	<ol style="list-style-type: none"> 1. Adjust the cutting deck bolt, make sure the deck is not loose. Please balance the deck level after each adjustment. 2. Replace with a new cutting deck.
The machine cuts the grass abnormally.	<ol style="list-style-type: none"> 1. The grass is too wet. 2. The grass amount you set is too much. 	<ol style="list-style-type: none"> 1. Please check the grass before working. If the grass is too wet, please wait until the grass gets drier. 2. If the grass is too intensive and high, raise the deck height, and avoid cutting intensive grass.
The machine vibrates too much.	<ol style="list-style-type: none"> 1. The blade is loose. 2. The blade is bent. 3. The deck is uneven. 4. The deck is loose. 5. The blade cuts too much grass more than the amount you set. 	<ol style="list-style-type: none"> 1. Grind the blade according to the manual. 2. Replace the bent blade, replace the blade according to the instructions in the manual, and wear protective equipment. 3. Adjust the cutting deck according to the instructions in the manual to ensure the left and right deck height are even. 4. Tighten the fixing bolts of the deck. 5. If the grass is too intensive and high, please raise the cutting deck and try to avoid cutting intensive grass.
There is grass or debris on the ground after mowing.	<ol style="list-style-type: none"> 1. The blade cuts too much grass more than the amount you set. 2. The grass is too wet. 3. You drive too fast. 4. The blade speed is too low. 	<ol style="list-style-type: none"> 1. If the grass is too dense and high, please raise the cutting deck. If the grass height exceeds 6 inch, please cut the area repeatedly. Try to avoid cutting intensive grass. 2. Please check the grass before working. If the grass is too wet, please wait until the grass gets drier. 3. Reduce the drive speed. 4. Turn the blade speed to high position.
The cutting endurance time is short.	Heavy grass can short the running time of the lawn mower.	Raise the cutting deck and reduce the blade speed to extend the running time.
The machine is off the track.	The tire pressure of the left and right rear wheel is different.	Check the tire pressure of the machine regularly according to the instructions.
The machine fails to start after cleaning.	Improper cleaning, water enters electronic components such as LCD or battery compartment.	<ol style="list-style-type: none"> 1. When cleaning the machine, please clean it according to the instructions. 2. If the vehicle is accidentally exposed to rain, please put the vehicle in a dry place for 12 hours or dry it before use. 3. Contact a service center for help.
The mower is blocked.	The deck is full of weeds and garbage.	Please clean the machine correctly according to the instructions after each use.

Problem	Cause	Solution
The machine quickly moves down the slope even if you engage the neutral bypass knob.	<ol style="list-style-type: none">1. Tire wear is too serious.2. The neutral bypass knob is damaged or severely worn out.3. Check if the neutral bypass knob is disengaged by someone.	<ol style="list-style-type: none">1. Contact a service center to replace the tire or neutral bypass knob.2. Check if the neutral bypass knob is disengaged by someone.

18 TECHNICAL DATA

Model No.	CRZ426	CRZ428	CRZ428
Voltage	60 V	80 V	82 V
Gross vehicle weight (lbs)	234±3	234±3	234±3
Length	67"	67"	67"
Height	46"	46"	46"
Width (with discharge)	53"	53"	53"
Deck width	42"	42"	42"
Forward speed (mph)	7.5	7.5	7.5
Reverse speed (mph)	3	3	3
Cutting height range	1.5-4.5"	1.5-4.5"	1.5-4.5"
Bucket capacity (lbs)	200	200	200
Towing capacity(lbs)	300 (include bucket capacity)		
Battery model	See website		
Charger model	See website		

19 WARRANTY

Greenworks hereby warrants this product, to the original purchaser with proof of purchase, for a period of four (4) years or 200 hours of use (whichever comes first) against defects in materials, parts or workmanship. Greenworks, at its own discretion, will repair or replace any and all parts found to be defective, through normal use, free of charge to the customer. This warranty is valid only for units which have been used for personal use that have not been hired or rented for industrial/commercial use, and that have been maintained in accordance with the instructions in the owners' manual supplied with the product from new.

19.1 ITEMS NOT COVERED BY WARRANTY:

- Any that have been transferred to a new owner. This warranty only applies to the original purchaser from an authorized Greenworks retailer or dealer. This warranty is nontransferable.
- Any part that has become inoperative due to misuse, rental use, commercial use, abuse, neglect, accident, improper maintenance, product modification, unauthorized repair or alteration; or
- If item has not been operated and/or maintained in accordance with the owner's manual; or
- Normal wear.
- Routine maintenance parts or service include, but are not limited to: lubricants, mower seat wear, blade sharpening, wheels, tirs, anti-scalp wheels, blades as well as any optional accessories or attachments.

- Normal deterioration of the exterior finish due to use or exposure.
- Damage or failure resulting from, but not solely: immersion in water or other liquids, accidents, misuse, neglect or lack of proper installation, and proper maintenance and storage.
- An item that has not been registered on an authorized Greenworks website (see REGISTRATION info with QR code or product page info for proper product registration).

19.2 HELPLINE:

Warranty service is available by calling our toll-free helpline, at 1-888-909-6757 Greenworks Pro, 1-855-470-4267 Greenworks Commercial.

19.3 TRANSPORTATION CHARGES:

Transportation charges for the movement of any power equipment unit or attachment are the responsibility of the purchaser. It is the purchaser's responsibility to pay transportation chares for any part submitted for replacement under this warranty unless such return is requested in writing by Greenworks.

USA address:

Greenworks Tools
P.O. Box 1238
Mooresville, NC 28115

Canadian address:

Greenworks Tools Canada Inc.
P.O. Box 93095, Newmarket,
Ontario
L3Y 8K3